

Date/Data: 07.08.2024

Time/Czas: 19:30

Subject/Temat: BULLETIN NO. 3 / KOMUNIKAT NR 3

Doc. No / Dok. Nr: 1.3

From/Od: The Clerk of the Course / Dyrektora Zawodów





To/Do: All competitors - crew members / Wszystkich zawodników –
członków załóg

Number of pages: 9

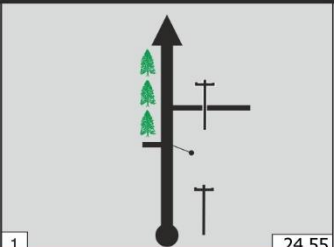

Liczba stron: 9

1. AMENDMENTS TO THE ROAD BOOK / ZMIANY W KSIĄŻCE DROGOWEJ

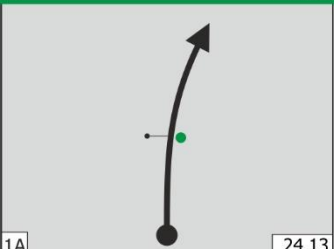
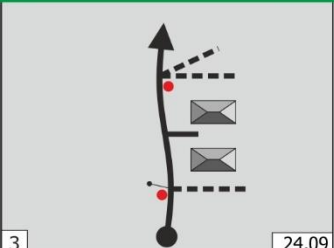

Page 63, box 1-3

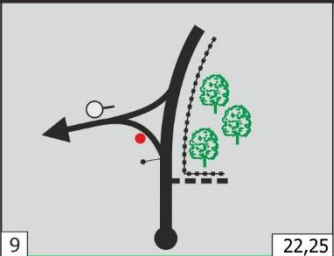
| | | | | |
|------|-------------|---|---|---------------|
| 0,00 | --- |  |    | NEW 41,43 |
| 0,42 | 0,42 |  | DNC 0 NEW BOX | NEW 41,01 |
| 0,46 | 0,04 |  | DNC 1 DNC 2 | 2023 40,97 |

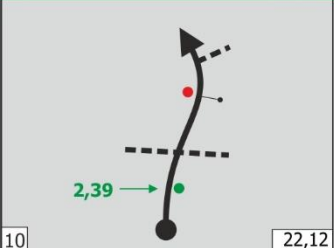
Page 64, box 9-10

| | | | | |
|------|-------------|---|---|---------------|
| 2,30 | 0,40 |  | DNC 13  | 2023 39,13 |
| 2,43 | 0,13 |  | DNC 13A DNC 14 BOX MODIF. | NEW 39,00 |

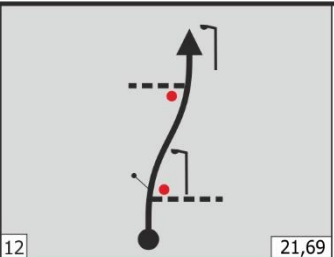
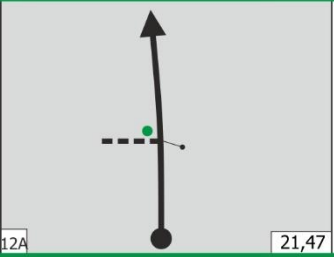
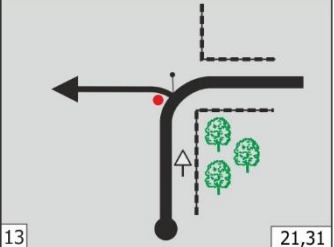

Page 65, box 12-13

| | | | | |
|------|-------------|---|--|---------------|
| 2,86 | 0,22 |  | DNC 16 DNC 17 | 2023 38,57 |
| 3,08 | 0,22 |  | DNC 17A NEW BOX | NEW 38,35 |
| 3,24 | 0,16 |  |  DNC 18 N-49° 55.593' E-21° 57.611' | 2023 38,19 |

Page 67-68, box 25-26

| | | | | | | |
|------|-------------|------------------|--------------------|---------|-------|-------|
| 6,49 | 0,20 | <p>25 18,06</p> | DNC 34 | 2021 | 34,94 | |
| 6,72 | 0,23 | <p>25A 17,83</p> | DNC 34A DNC 34B | NEW BOX | NEW | 34,71 |
| 6,91 | 0,19 | <p>25E 17,64</p> | DNC 34C DNC 34D | NEW BOX | NEW | 34,52 |
| 7,10 | 0,19 | <p>25C 17,45</p> | DNC 34E | NEW BOX | NEW | 34,33 |
| 7,15 | 0,05 | <p>26 17,40</p> | DNC 35 | | 2021 | 34,28 |

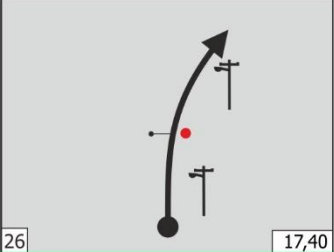
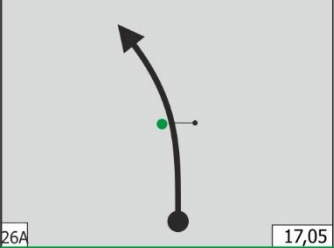
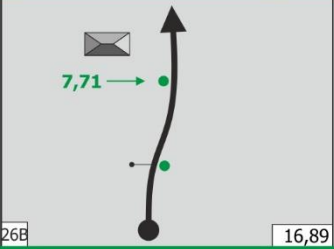
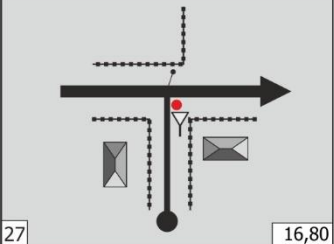
Page 68, box 26-27

| | | | | | |
|------|-------------|---|--|------|-------|
| 7,15 | 0,05 |  | DNC 35 | 2021 | 34,28 |
| 7,50 | 0,35 |  | DNC 35A NEW BOX | NEW | 33,93 |
| 7,66 | 0,16 |  | DNC 35B DNC 35C NEW BOX | NEW | 33,77 |
| 7,75 | 0,09 |  | DNC 36   | 2021 | 33,68 |

Page 69, box 33-34

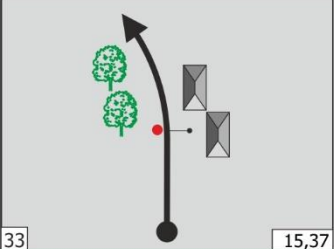
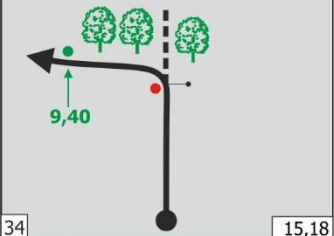
| | | | | | | |
|------|-------------|---|-------------------|-------------------|------------|-------|
| 9,18 | 0,13 |  | DNC 45 | NEW | 32,25 | |
| 9,37 | 0,19 |  | DNC 46 DNC 46A | BOX MODIF. | NEW | 32,06 |

Page 71, box 43-44

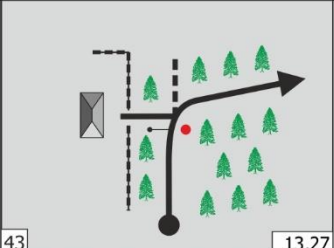
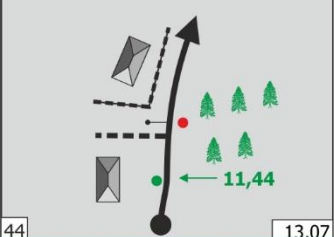
| | | | | | | |
|-------|-------------|---|-------------------|-------------------|------------|-------|
| 11,28 | 0,15 |  | DNC 59 | NEW | 30,15 | |
| 11,48 | 0,20 |  | DNC 59A DNC 60 | BOX MODIF. | NEW | 29,95 |

Page 72, box 46-47

| | | | | |
|-------|-------------|--|--|---------------------|
| 12,54 | 0,36 | | R-S DNC 67 DNC 68 N-49° 55.844' E-21° 57.209' | 2023 28,89 |
| 12,92 | 0,38 | | DNC 0 NEW BOX | NEW 28,51 |
| 12,96 | 0,04 | | DNC 1 DNC 2 | 2023 28,47 |

Page 73 , box 54-55

| | | | | |
|-------|-------------|--|-------------------------------------|---------------------|
| 14,80 | 0,40 | | DNC 13 | 2023 26,63 |
| 14,93 | 0,13 | | DNC 13A DNC 14 BOX MODIF. | NEW 26,50 |



Page 74, box 57-58

| | | | | |
|-------|-------------|--|---|---------------|
| 15,36 | 0,22 | | DNC 16 DNC 17 | 2023 26,07 |
| 15,58 | 0,22 | | DNC 17A NEW BOX | NEW 25,85 |
| 15,74 | 0,16 | | DNC 18 N-49° 55.593' E-21° 57.611' | 2023 25,69 |

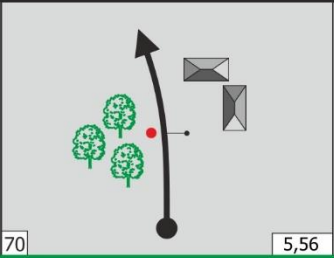
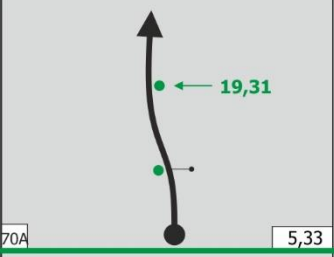
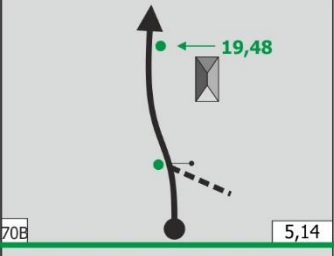
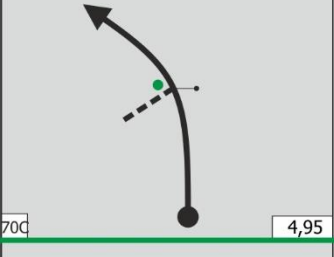
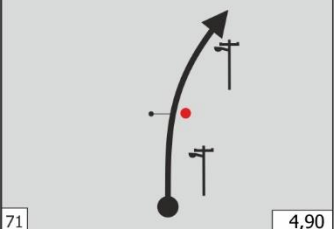
Page 76-77, box 70-71

| | | | | | | |
|-------|-------------|---|--------------------|---------|-------|-------|
| 18,99 | 0,20 |  | DNC 34 | 2021 | 22,44 | |
| 19,22 | 0,23 |  | DNC 34A DNC 34B | NEW BOX | NEW | 22,21 |
| 19,41 | 0,19 |  | DNC 34C DNC 34D | NEW BOX | NEW | 22,02 |
| 19,60 | 0,19 |  | DNC 34E | NEW BOX | NEW | 21,83 |
| 19,65 | 0,05 |  | DNC 35 | 2021 | 21,78 | |

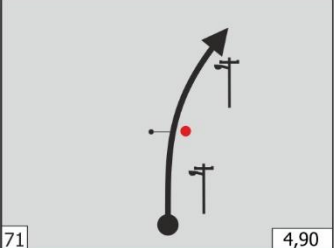
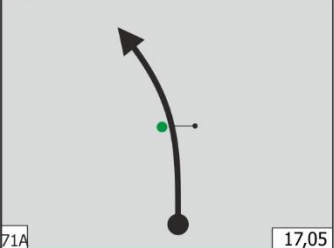
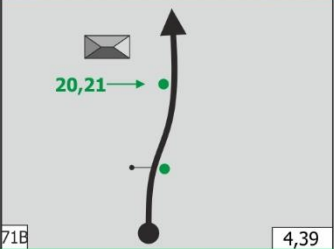
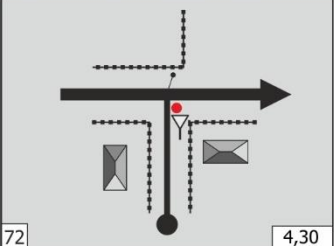
Page 77, box 71-72

| | | | | | | |
|-------|-------------|---|--------------------|--|-------|-------|
| 19,65 | 0,05 |  | DNC 35 | 2021 | 21,78 | |
| 20,00 | 0,35 |  | DNC 35A | NEW BOX | NEW | 21,43 |
| 20,16 | 0,16 |  | DNC 35B DNC 35C | NEW BOX | NEW | 21,27 |
| 20,25 | 0,09 |  | DNC 36 |   | 2021 | 21,18 |

Łukasz Biegus
Clerk of the Course
Dyrektor Rajdu